

## Creating a home for hedgehogs

Written by Richard Burkmar

If you have hedgehogs (*Erinaceus europaeus*) in your garden you will almost certainly have seen them; although chiefly nocturnal, they will often be seen about the garden by daylight - especially in the evening. Hedgehogs are welcomed by most gardeners: they cause little or no harm and do a very good job of keeping slug numbers down. For many of us they are special because they are generally the largest mammal that we regularly see in our gardens. (Relatively few people are lucky enough to be visited by badger, fox or deer.) You can encourage hedgehogs to make even more use of your garden by providing a place for them to nest and/or hibernate.

A lean-to shelter for hedgehogs

As with most homes for wildlife, there is no need to spend a lot of money if your budget is tight. The simplest way of building a hedgehog shelter is to make a sort of lean-to by placing an old board against a wall, fence or other structure and covering it in leaves, compost, soil, or branches. The gap under the board will provide a relatively dry shelter which a hedgehog might find suitable for hibernation. You can rake some dry leaves into that gap or provide a little dry straw if you wish, but a hedgehog is also capable of bringing material in itself.



### Hedgehog lean-to

This is a very economical way of making a shelter for hedgehogs which is ideal for hibernation.



◀ An old piece of plywood (not much use for anything else) has been leant over a pile of dry leaves against a stick pile.

The lean-to has been covered with logs and sticks to secure the board from the wind and to improve its appearance. ▶



Hedgehog box purchased from the RSPB.

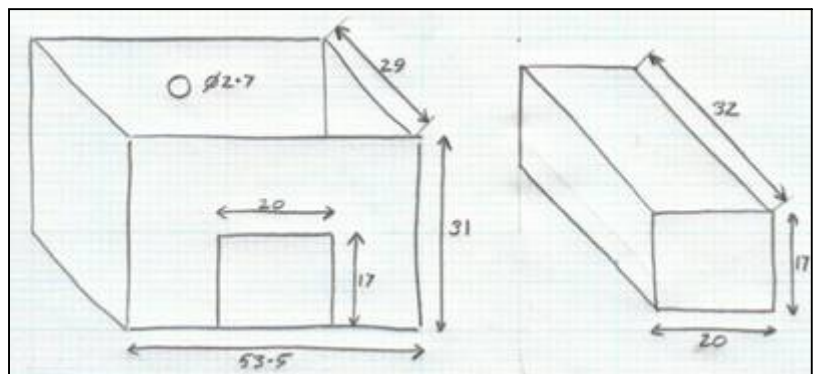

Dimensions in centimetres of hedgehog box purchased from the RSPB.

### A more ambitious shelter

If your budget is larger and/or you have reasonable DIY skills, you might consider buying or making a more ambitious shelter which can be used for hibernation in the autumn and winter or for nesting in the summer. The box pictured above was purchased from the RSPB, but you might consider making one yourself if you can get hold of the materials.

This box was constructed almost entirely from 1cm 7-ply plywood. If you are making your own, your box will survive the elements longer if you can afford external quality (marine) plywood. The sides were held together by fixing them to supporting battons (2.5x2cm softwood). Two runners of the same softwood were also used on the base of the box to prevent it from coming into direct contact with the ground. A 20cm long plastic tube (here 2.7cm in diameter) was used as a vent in the back of the box (simply pushed snugly into a hole of the same diameter). Of course you can modify the dimensions and materials somewhat to suit those you have available: hedgehogs are not that fussy!

Note that in natural situations, hedgehog nesting and hibernation sites are generally reasonably well ventilated. Because this type of constructed box is 'unnaturally' well enclosed, we must pay special attention to ventilation. When positioning the box, it is vital to ensure that the ventilation tube clears any material placed over the box and that it is angled slightly downwards to prevent moisture running into the box.

### Deploying a hedgehog box

These pictures will give you a good idea of how this hedgehog box was constructed and also show how it can be deployed in the garden.



Here you can see how this box was constructed. Battons are used to join the plywood sides and on the underside of the roof to prevent it sliding off the box when in place.



The tunnel entrance of the box is a simple construction. A batton on the underside of the front edge of the tunnel prevents it from coming into contact with the ground.



The tunnel entrance is placed a little way into the box. You can put some nesting material in the box to encourage the hedgehogs. Here I've used straw (avoid hay as it can entangle hedgehogs).



Here is the box with the lid and ventilation tube in place. Note how the ventilation tube is angled slightly downwards.



Choose a relatively undisturbed, sheltered and preferably 'wild' part of the garden in which to position the box. This site was on a slight slope so I levelled it with a trowel before deploying the box.



Rather than place the box directly onto the soil I have put it on some plastic (scrap pond liner) in order to prolong its life.



Before covering the box with leaves etc, place some old roofing felt or plastic (I've used scrap pond liner) in order to protect the box from damp and extend its life.



Finally, cover the whole construction, apart from the tunnel entrance and the vent, with leaves, compost, soil or branches. This will insulate the box and give it a more natural appearance (both to you and a hedgehog).



Have patience!

A good time to create a shelter like either of those shown above is around September time, just before hibernation begins or in early spring before breeding starts. But you shouldn't feel constrained to wait for the 'right time' to build a shelter: just do it when the opportunity arises. If you want to clean out an established shelter, do it around late August or September after hedgehogs have finished breeding, but before they have started hibernation.

Once your shelter is in place be patient and don't be *too* disappointed if hedgehogs don't use the box right away. Even if hedgehogs don't use your shelter at all, what is certain is that some garden animal or another will. Perhaps voles or wood mice might find shelter in your 'hedgehog' lean-to: it might not be what you expected but you will, nevertheless, have made a valuable contribution towards enriching the wildlife habitat that is your garden.

First published August 2004.

Copyright Richard Burkmar 2004. Permission is hereby granted for anyone to use this article for non-commercial purposes which are of benefit to the natural environment as long the original author is credited. School pupils, students, teachers and educators are invited to use the article freely. Use for commercial purposes is prohibited unless permission is obtained from the copyright holder.